

KF-0150 Undercounter Ice Kube Machine

Models

- KDF-0150A KYF-0150A



Koolaire KF-0150

- Up to 169 lbs (77 kg) of daily ice production
- Only 26" wide (66.0 cm), 26.5" (67.3 cm) deep and 38.5" (98.8 cm) high with 6" (15.24 cm) legs
- Cabinet volume is 3.107 ft³ (.088 m³) 92 lbs (42 kg) ice storage capacity*

* Application capacity based on 90% volume X 33 lbs / ft³ average density of ice

Specifications

BTU Per Hour:

2,700 (average) and 3,300 (peak)

Compressor:

Nominal rating: .33 HP

Cupra-Nickel Condenser: (Water-cooled models) Adds protection from corrosive water elements

Refrigerant:

R-404A

Operating Limits:

- Ambient Temperature Range: 40° to 110° F (4.4° to 43.3° C)
- Water Temperature Range: 45° to 90° F (4.4° to 32.2° C)
- Water Pressure Ice Maker Water In: Min. 20 psi (137.9 kPa) Max. 80 psi (551.1 kPa)

Features

- Simple controls, convenient, reliable and long lasting.
- Simple 3-way switch for on/off/clean. No need to remove the front panel.
- Front air intake and discharge.
- Easy to remove, re-usable air filter to keep the condenser cleaner.
- Two ice sizes to choose from: Kube and Half Kube.
- Hideaway bin door slides under the ice machine top.

Ice Machine Electric

Power Cord:

115/60/1 ice machines are factory pre-wired with a 6' (180 cm) power cord and NEMA 5-15P-plug configuration

Total Amps:

115/60/1 Air-cooled: 7.2 Amps

Maximum fuse size:

Air-cooled: 15 amps
HACR-type circuit breakers can be used in place of fuses

Ice Shape



HALF KUBE

3/8" x 1 1/8" x 7/8"
(.95 x 2.86 x 2.22 cm)

❄️ = 100%
⬇️



KUBE

7/8" x 7/8" x 7/8"
(2.22 x 2.22 x 2.22 cm)

❄️ = 100%
⬇️



KF-0150

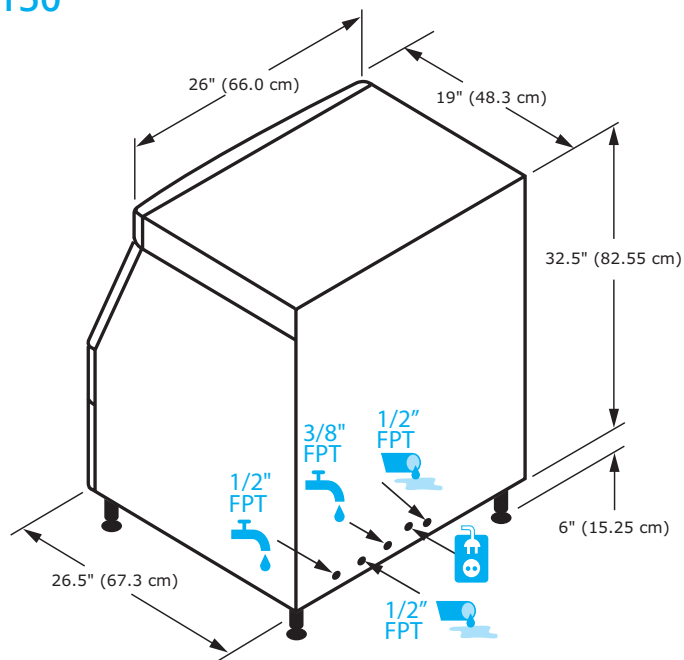

Installation Note: Recommended clearance for top, sides, and back is 5" (127 cm). However, there is no minimum clearance required.

Space-Saving Design



	KF0150
Height	38.5" 97.8 cm
Width	26.00" 66.0 cm
Depth	26.5" 67.3 cm
Bin Storage	92 lbs. 42 kgs.

Measurements with bin legs at 6.00" (15.25cm). Adjustable bin legs 6.00" to 8.00" (15.24cm to 20.32cm). Bin capacity is based on 90% of the volume x 33 lbs/ft³ average density of ice.

Specifications

	Model	Ice Shape	Ice Production 24 Hours		Power Usage kWh/100 lbs. @90°Air/70°F	Potable Water Usage/100 lbs. 45.4 kgs. of Ice
			70°/ 50°F 21°/ 10°C	90°/ 70°F 32°/ 21°C		
AIR COOLED	KDF-0150A	kube	168 lbs.	110 lbs.	9.35	32 Gal.
			76 kgs	50 kgs		121 L
	KYF-0150A	half-kube	169 lbs.	114 lbs.	9.1	32 Gal.
			77 kgs	52 kgs		121 L

Standard 6" / 15.24 cm adjustable flange foot - gray painted legs included.

Standard plastic ice scoop included.

Shipping Weight:

Air-cooled: 154.3 lbs (70 kg)



Accessories

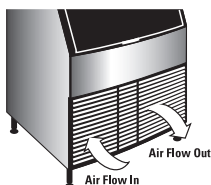

Air Flow Top View

Air in left, air out right, no side vents. Great for installation under countertops and next to other equipment.



Air Filter

Slides out from left side front without tools, easy to clean, reusable filter protects condenser from lint, grease and dust.

Arctic Pure® Water Filters

Reduces sediment and chlorine odors for better tasting ice.



Welbilt reserves the right to make changes to the design or specifications without prior notice.