



BEVERAGE-AIR

Project: _____

AIA#

Item: _____

Location: _____

SIS#

Approved: _____

FLG BAR EQUIPMENT

FLG24HC Solid Door Glass Froster
Hydrocarbon Series

MODELS:
FLG24HC-1-S
FLG24HC-1-B

FLG24HC BAR EQUIPMENT: GLASS FROSTER SERIES

3 Year Parts/Labor Warranty
Additional 4 Year Compressor Warranty

CABINET CONSTRUCTION



- Stainless steel front, sides and door, (galvanized back and bottom)
- Interior liner is made of corrosion resistant aluminum
- Stainless steel top
- Full electronic control
- Interior thermometer is standard
- Self closing door with 120° stay open feature, on cartridge style hinges
- Door opening includes low wattage, anti-condensate heaters
- Magnetic gasket for positive seal
- 2 Epoxy coated shelves standard
- Painted aluminum door handle
- Field reversible door
- Automatic defrost of coil is standard
- Built-in condensate evaporator system
- No floor drain or additional plumbing

OPTIONS & ACCESSORIES

- Black exterior model
- Casters
- Stainless steel back and grille
- Stainless steel interior
- Remote option* (see note on back page)

REFRIGERATION SYSTEM

- Refrigeration system uses R290 refrigerant to comply with all environmental concerns
- Automatic, electric defrost
- Epoxy coated evaporator coil
- Chills glasses and plates at -10°F



3779 Champion Blvd., Winston-Salem, NC 27105
1-888-845-9800 Fax: 1-336-245-6453
Beverage-Air.com sales@bevair.com



BEVERAGE-AIR

Bar Equipment - Glass Froster

Models: FLG24HC-1-B, FLG24HC-1-S

MODEL	FLG24HC-1-B	FLG24HC-1-S
EXTERNAL DIMENSIONAL DATA		
Width Overall	24"	24"
Depth Overall with Handle	30 1/8"	30 1/8"
Height Overall	32"	32"
Number of Doors	1	1
Door Opening 90°	50 5/8"	50 5/8"
Door Opening (in)	19 5/8" x 21 5/8"	19 5/8" x 21 5/8"
INTERNAL DIMENSIONAL DATA		
NET Capacity (cubic ft.)	5.06	5.06
Internal Width Overall (in)	20"	20"
Internal Depth Useable (in)	18 1/4"	18 1/4"
Internal Height Overall (in)	23"	23"
Number of Shelves	2	2
ELECTRICAL DATA		
Full Load Amperes 115/60/1	2.5	2.5
REFRIGERATION DATA		
Horsepower	1/4	1/4
Capacity (BTU/Hr)*	858	858
WEIGHT DATA		
Gross Weight (Crated lbs)	208 lbs	208 lbs
Height - Crated	41"	41"
Width - Crated	30"	30"
Depth - Crated	32"	32"

*NOTE: Remote units are field wired and come with 6" legs.
Refrigerant must be specified at time of order.

Model Views

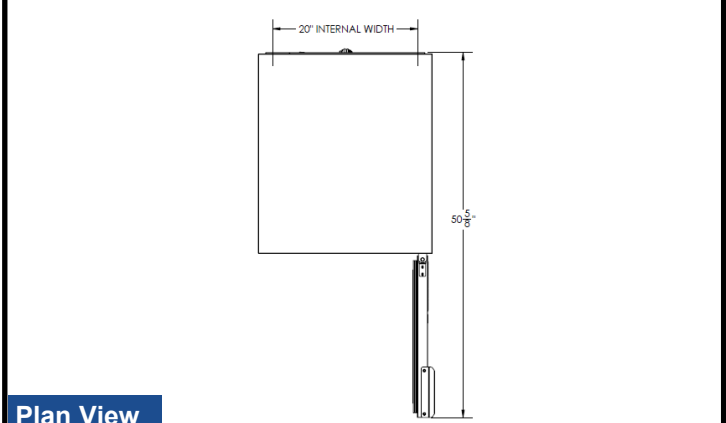

Plan View

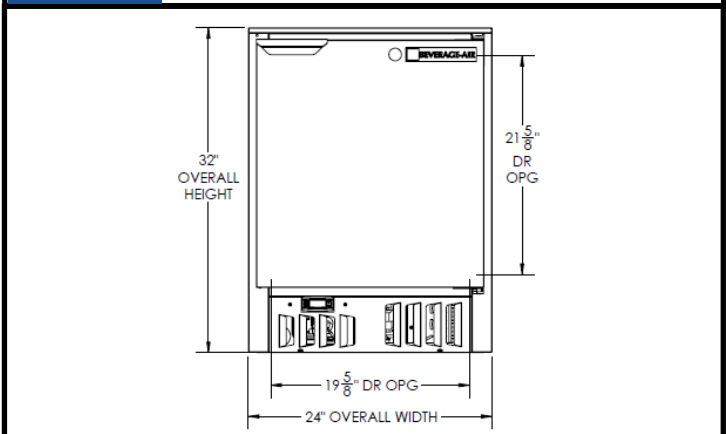

Elevation View

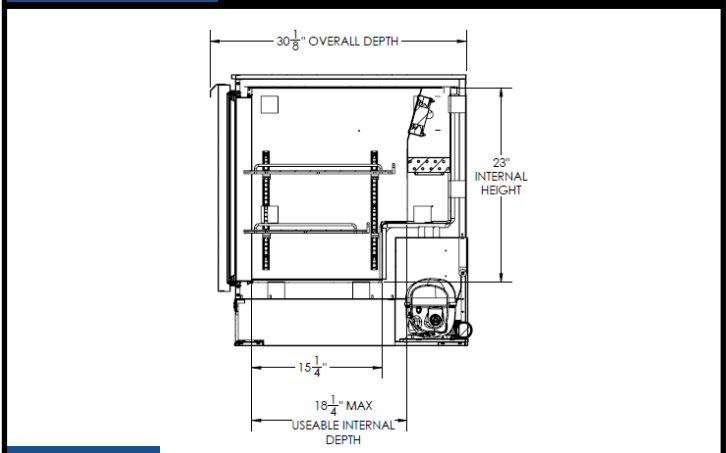

Side View

ELECTRICAL CONNECTION



115/60/1
NEMA-5-15P

Unit pre-wired at factory and include 8' long cord and plug set.



3779 Champion Blvd., Winston-Salem, NC 27105 1-888-

845-9800 Fax: 1-336-245-6453 Beverage-Air.com

an Ali Group Company



The Spirit of Excellence